

ES SOCKET WELD SQUAT LINE

HIGH PRESSURE TEST PLUGS

For hydrostatic testing of socket weld fittings

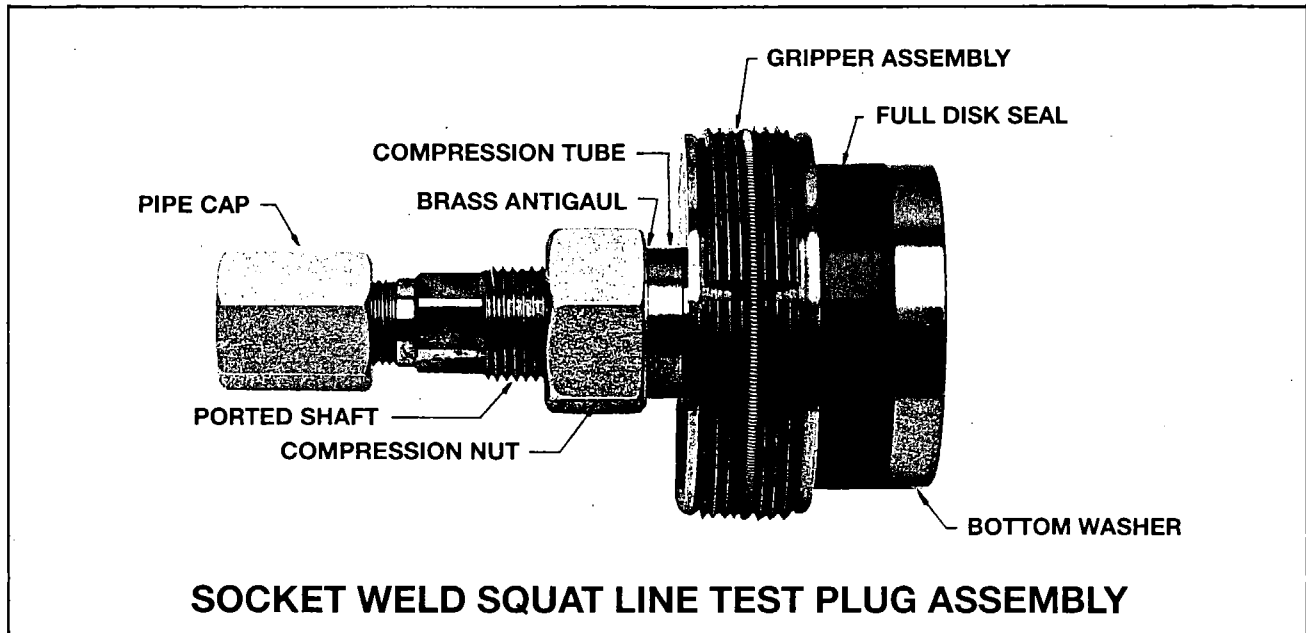

OPERATION

Insert the Socket Weld Squat Line into the socket weld fitting and tighten the large compression nut. The full disk seal will expand to seal the bore of the fitting. The grippers will expand into the socket area of the fitting to restrain the test plug. Attach a high pressure water supply to the plug and begin testing.

FEATURES

- Unique "Twin Cone" design provides uniform gripper expansion assuring 100% contact between the test plug and the socket weld fitting.
- Long wearing "Full Disk Seals" provide easy plug installation and removal.
- Socket Weld Squat Lines are supplied with a high pressure pipe cap.
- Fast service and delivery.
- Special Test Plugs for other pipe weld fittings are available. Contact the factory for additional information.



Expando Seal Tools Inc.

123 Keystone Drive, Montgomeryville, PA 18936-9638 USA
215-643-7044 • FAX 215-641-9765

The Specialist in Pipe and Tube Testing and Plugging Systems.

